



10 KG FRONT LOAD WASHER AND STACKED DRYER

Features and Benefits

- Low water consumption of only 44.3 litres per wash with full wash completed in 30 minutes.
- Energy saving 'High Speed Extract' spin cycle of 1,200 rpm producing 'G' forces in excess of 440 for greater water removal, resulting in reduced drying times and associated energy savings.
- 100% front service dryer.
- Touch push button controls robust and easy to use controls suitable for high volume multiple operator applications.

SPECIFICATIONS

DIMENSIONS	
CAPACITY	10 kg washer, 9 kg dryer
WIDTH	683 mm
DEPTH	796 mm
HEIGHT	1,986 mm
NET WEIGHT	177 kg
OPERATION	
CYCLES	5 Wash Cycles - 4 Dry Cycles
CYCLE LIGHTS	Yes
CYCLE TIME	26 - 30 minutes
CONTROLS	Touch push button controls
ACTIVATION	Push to start multi cycle control
WATER TEMPERATURE	Cold, Warm or Hot
MOTOR (WASHER)	1 hp, variable speed
SPEED (WASHER)	500 - 1,200 rpm, variable speed
WATER USE (WASHER)	44.3 litres / wash
HEAT INPUT (DRYER)	4,000 w
CONSTRUCTION	
DRUM (WASHER)	Stainless steel
OUTER BOWL (WASHER)	Stainless steel
OUTER CABINET	Steel
DRUM (DRYER)	Galvanised



STEBXA Commercial Washer/Dryer



TECHNICAL SPECIFICATIONS

WASHER UTILITIES

10 AMP SINGLE PHASE 240 V 50 HZ
10 AMP CIRCUIT-BREAKER REQUIRED
1.8 M POWER LEAD
HOT AND COLD WATER CONNECTIONS REQUIRED
1.2 M HOT AND COLD WATER HOSES SUPPLIED
WATER SUPPLY HOSE TAP ENDS 3/4 BSP THREADS
MAX HOT WATER CONSUMPTION 18.7 LITRE / CYCLE
MAX WATER CONSUMPTION 44.3 LITRE / CYCLE
MAX POWER DRAW 750 W / HR
DRAIN: 610 - 914 MM UPSTAND, 50 MM DIAMETER
WATER SUPPLY PRESSURE BETWEEN 140-820 KPA

UTILITIES DRYER

20 AMP SINGLE PHASE	240 V 50 Hz
20 AMP	Circuit-breaker required
1.8 M	Power Cord
FLUE DIAMETER	102 mm (4 in)
AIR FLOW	85 litres / second
MAX POWER DRAW	4,000 w / hour
OPTIONAL	Right or left side venting

SHIPPING DIMENSIONS

WEIGHT	193 kg
HEIGHT	2,032 mm
WIDTH	737 mm
DEPTH	832 mm
	1.25 m ³

- A) *1678 mm B) *1447 mm C) 597 mm
 F) 203 mm G) 391 mm H) 59 mm
 K) *1140 mm L) *813 mm M) 683 mm
 P) 52 mm Q) 704 mm R) 38 mm

*With leveling legs turned into base.

- D) 213 mm E) 610 mm
 I) *938 mm J) *368 mm
 N) *1184 mm O) *1986 mm
 S) *333 mm

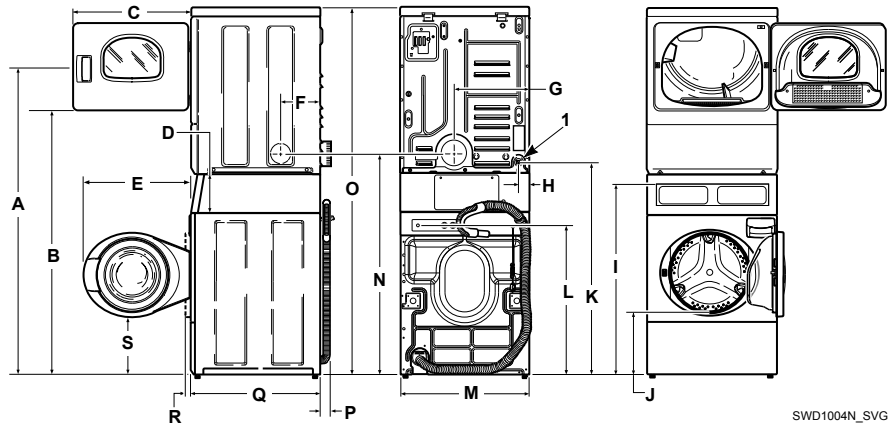

SWD1004N_SVG

WESTERN AUSTRALIA

7/15 Walters Drive
 Osbourne Park WA 6017
 T: 08 9445 7744
 enquiry@speedqueenwa.com.au

NEW SOUTH WALES & ACT

245 Rawson Street
 Auburn NSW 2144
 T: 02 9748 2155
 enquiry@speedqueenlaundry.com.au

SOUTH AUSTRALIA & NT

385-387 Main North Road
 Enfield SA 5085
 T: 08 7095 0336
 sa@speedqueenlaundry.com.au

QUEENSLAND

2/18 Gravel Pit Road
 Darra QLD 4076
 T: 07 3376 3869 *Home retail
 qld@speedqueenlaundry.com.au

*For the most accurate information, the installation guide should be used for all design and construction purposes. Due to continuous product improvements, design and specifications are subject to change without notice.