



SPEED QUEEN® QUANTUM® TOUCH
Washer-Extractors

SC020
20 lb (9 kg)

SC030
30 lb (14 kg)

SC040
40 lb (18 kg)

SC060
60 lb (27 kg)

SC080
80 lb (36 kg)

SC100
100 lb (45 kg)

Quantum® Touch Control

Reimagine your laundry experience with the Speed Queen Quantum Touch display. Clear, easy to use, easy to understand directions with profitable cycle modifiers enhance your customers' experience and increase return on investment.

- 7", full color, touch screen display
- User-friendly screen with operating instructions built in as part of the control
- 11 basic cycles, 1 custom cycle, 15°C - 90°C temperature selections

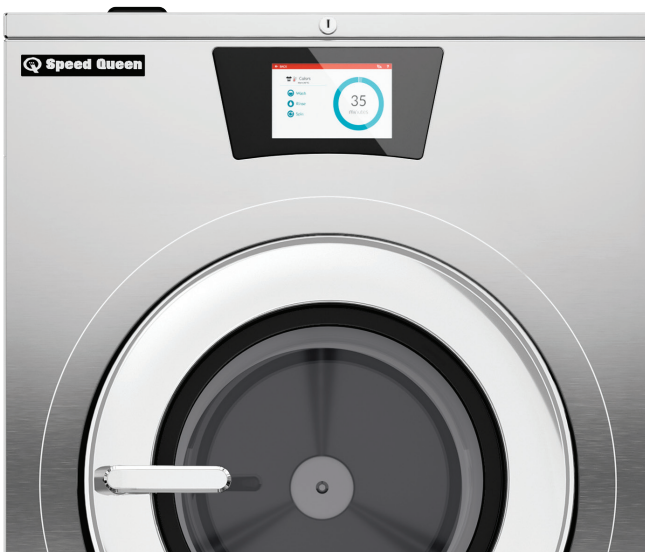
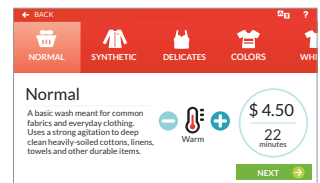

- Easy-to-understand cycle modifier prompts will encourage your customers to customize their wash
- Flexible pricing & additional revenue opportunities with customizable cycle modifiers, time-of-day pricing and lucky cycle options
- 30+ languages available
- On screen timer so your customers know exactly how much time their cycle will take
- Speed Cycle option for those who want to get in and out quickly
- Flexible Payment Options - Coin, Card, Mobile, Cash

Hardmount Washer-Extractors

A heavy-duty design meets superior machine mechanics to form the industry's most trusted hardmount washer-extractor.

- Strong frame lasts longer, balances loads more efficiently, and is designed to reduce sound and vibration levels
- Advanced inverter drive system provides smooth, reliable performance
- Higher extraction speeds mean shorter dry times and lower energy bills
- Sump system design maximizes cleaning power while using 7% less water
- Leak detection with our patented Water Guardian, saves water by detecting slow or leaking fill-valves and drains
- Easily serviceable with front panel access

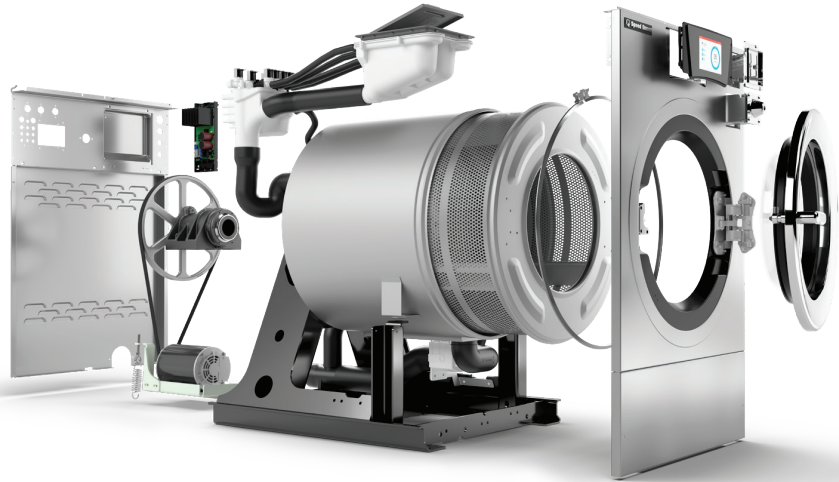

SPEED QUEEN®
INSIGHTS
READY

Take your business to new levels of efficiency and profitability with advanced analytics and customer data—all integrated into the same platform with the rest of your business management tools. Know how often each customer visits, which machines they use, how they pay, and use that information to increase your revenue through stronger customer relationships and a more rewarding laundry experience.

Hardmount Washer-Extractors

		SC020	SC030	SC040	
Control Option		Quantum Touch	Quantum Touch	Quantum Touch	
Capacity - lb (kg)		20 (9)	30 (13.6)	40 (18)	
Overall Width - in (mm)		26 (660)	29 (737)	30.6 (777)	
*Overall Depth - in (mm)		30.9 (785)	35.3 (897)	42.3 (1074)	
Overall Height - in (mm)		43 (1092)	45 (1143)	47.2 (1199)	
Cylinder Diameter - in (mm)		21 (533)	24 (610)	26.3 (668)	
Cylinder Depth - in (mm)		13.8 (351)	16 (406)	20.3 (516)	
Cylinder Volume - cu. ft (liters)		2.8 (79)	4.2 (119)	6.3 (178)	
Door Opening Size - in (mm)		11.6 (295)	14.3 (363)	16.3 (414)	
Door Bottom to Floor - in (mm)		14.4 (366)	14 (356)	14.6 (371)	
Water Inlet Connection - in (mm)		2 x 0.75 (19)	2 x 0.75 (19)	2 x 0.75 (19)	
Drain Diameter - in (mm)		1 x 3 (76)	1 x 3 (76)	1 x 3 (76)	
Drain Height to Floor - in (mm)		3.9 (99)	4.3 (109)	4.5 (114)	
Motor Power Consumption - HP (kW)		1 (0.75)	1 (0.75)	2 (1.5)	
Total # of Speeds		9	9	9	
Cylinder Speeds - RPM (G-Force)		Gentle	37 (0.4)	34 (0.4)	33 (0.4)
		Wash	51 (0.8)	48 (0.8)	46 (0.8)
		Distribution	92 (2.5)	86 (2.5)	82 (2.5)
		Very Low	301 (27)	282 (27)	269 (27)
		Low	518 (80)	485 (80)	464 (80)
		Medium	579 (100)	542 (100)	518 (100)
		High	648 (125)	606 (125)	579 (125)
		Very High	710 (150)	664 (150)	635 (150)
		Ultra High	819 (200)	766 (200)	733 (200)
*** Voltage/Circuit Breaker - FLA	B	120/60/1	15-9	15-12	20-15
	X	200-240/50-60/1/3	15-4 (1 Ph) 15-3 (3 Ph)	15-7 (1 Ph) 15-4 (3 Ph)	15-7 (1 Ph) 15-4 (3 Ph)
	Y	220-240/60/1/3 (Pump Drain Only)	15-4 (1 Ph)	15-7 (1 Ph) 15-4 (3 Ph)	15-7 (1 Ph) 15-4 (3 Ph)
	N	440-480/50-60/3	15-2	15-3	15-3
Shipping Dimensions Approx.- in (mm)		Width	28 (711)	31.5 (800)	32.5 (826)
		Depth	33.8 (859)	38.3 (973)	43.5 (1105)
		Height	49.4 (1255)	51.3 (1303)	53.0 (1361)
Packed (with crate) Dimensions Approx.- in (mm)		Width	32.5 (826)	36.0 (915)	37.0 (940)
		Depth	36.8 (935)	41.3 (1050)	45.9 (1166)
		Height	55.0 (1397)	55.0 (1397)	55.6 (1413)
Net Weight - lb (kg)		340 (154)	440 (200)	540 (245)	
Shipping Weight - lb (kg)		380 (172)	480 (218)	580 (263)	
Slat Crate Shipping Weight - lb (kg)		460 (209)	580 (263)	680 (308)	
****Agency Approvals		UL _c US	UL _c US	UL _c US	

Hardmount Washer-Extractors

		SC060	SC080	SC100
Control Option		Quantum Touch	Quantum Touch	Quantum Touch
Capacity - lb (kg)		60 (27)	80 (36)	100 (45)
Overall Width - in (mm)		34.1 (866)	41.5 (1054)	41.5 (1054)
*Overall Depth - in (mm)		44.7 (1135)	47.1 (1196)	51.1 (1298)
Overall Height - in (mm)		49.9 (1267)	57.2 (1453)	57.2 (1453)
Cylinder Diameter - in (mm)		30 (762)	36 (914)	36 (914)
Cylinder Depth - in (mm)		22 (559)	21.9 (556)	25.9 (658)
Cylinder Volume - cu. ft (liters)		9.0 (255)	12.9 (365)	15.2 (430)
Door Opening Size - in (mm)		16.3 (414)	18.5 (470)	18.5 (470)
Door Bottom to Floor - in (mm)		14.9 (378)	17.9 (455)	17.9 (455)
Water Inlet Connection - in (mm)		2 x 0.75 (19)	2 x 0.75 (19)	2 x 0.75 (19)
Drain Diameter - in (mm)		1 x 3 (76)	1 x 3 (76)	1 x 3 (76)
Drain Height to Floor - in (mm)		4.9 (124)	5.1 (130)	5.1 (130)
Motor Power Consumption - HP (kW)		3 (2.2)	5 (3.7)	5 (3.7)
Total # of Speeds		9	9	9
Cylinder Speeds - RPM (G-Force)	Gentle	31 (0.4)	28 (0.4)	28 (0.4)
	Wash	43 (0.8)	39 (0.8)	39 (0.8)
	Distribution	77 (2.5)	70 (2.5)	70 (2.5)
	Very Low	252 (27)	230 (27)	230 (27)
	Low	434 (80)	396 (80)	396 (80)
	Medium	485 (100)	443 (100)	443 (100)
	High	542 (125)	495 (125)	495 (125)
	Very High	594 (150)	542 (150)	542 (150)
	Ultra High	686 (200)	626 (200)	568 (165)
** Voltage/Circuit Breaker - FLA	B	120/60/1	-	-
	X	200-240/50-60/1/3	15-11 (1 Ph) 15-7 (3 Ph)	20-15 (1 Ph) 15-9 (3 Ph)
	Y	220-240/60/1/3 (Pump Drain Only)	-	-
	N	440-480/50-60/3	15-4	15-6
Shipping Dimensions Approx.- in (mm)	Width	37.5 (953)	44 (1118)	44 (1118)
	Depth	46.9 (1191)	54.5 (1384)	58.5 (1486)
	Height	56.3 (1430)	59.6 (1514)	59.6 (1514)
Packed (with crate) Dimensions Approx.- in (mm)	Width	42.0 (1069)	48.5 (1232)	48.5 (1232)
	Depth	49.9 (1268)	57.5 (1461)	61.5 (1563)
	Height	64.0 (1626)	65.1 (1654)	65.1 (1654)
Net Weight - lb (kg)		680 (308)	1250 (567)	1280 (581)
Shipping Weight - lb (kg)		720 (327)	1300 (590)	1330 (603)
Slat Crate Shipping Weight - lb (kg)		840 (381)	1430 (649)	1460 (662)
***Agency Approvals		UL _{us}	UL _{us}	UL _{us}

*Overall depth includes vacuum breaker to door handle.

**Circuit breaker and amp draw data shown are for models without electric heat. Consult factory for other configurations. Manufacturer strongly recommends using a circuit breaker instead of fuses. Use 3-pole circuit breakers for 3-phase machines.

*** Agency approvals may vary depending on configuration. Consult factory for details. Steam connection requires 1/2" N.P.P.

For the most accurate information, the installation guide should be used for all design and construction purposes.

Due to continuous product improvements, design and specifications subject to change without notice. The quality management systems at Alliance Laundry Systems are registered to ISO 9001.

Hardmount Washer-Extractors

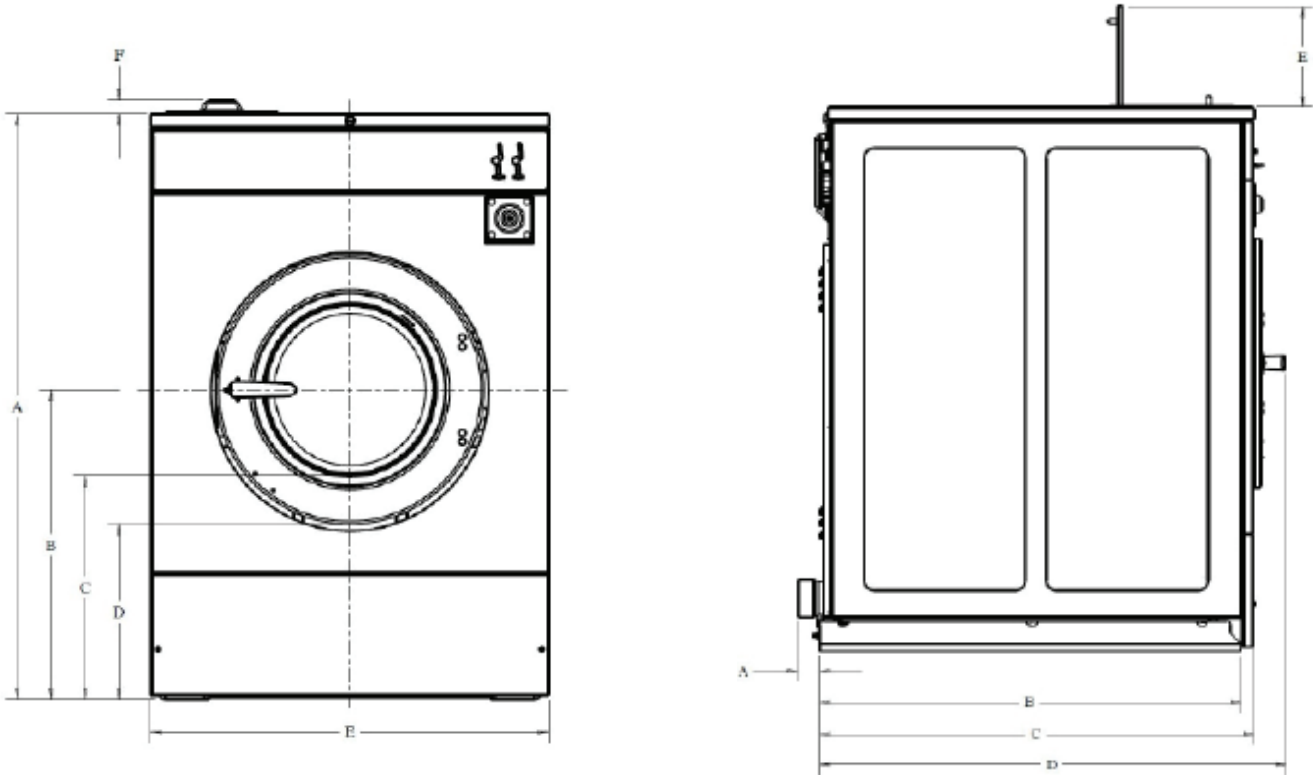

Dimensions - in (mm)		SC020	SC030	SC040	SC060	SC080	SC100
Front	A	43.0 (1093)	45.0 (1143)	47.2 (1199)	49.9 (1268)	57.2 (1453)	57.2 (1453)
	B	23.0 (585)	24.0 (610)	26.0 (661)	26.4 (671)	30.9 (785)	30.9 (785)
	C	17.0 (432)	17.0 (432)	17.7 (450)	18.1 (460)	21.7 (552)	21.7 (552)
	D	14.4 (366)	14.0 (356)	14.6 (371)	14.9 (379)	17.9 (455)	17.9 (455)
	E	26.0 (661)	29.0 (737)	30.6 (778)	34.1 (867)	41.5 (1055)	41.5 (1055)
	F	1.1 (28)	1.1 (28)	1.1 (28)	1.1 (28)	1.1 (28)	1.1 (28)
Side	A	2.0 (50.8)	2.0 (50.8)	2.0 (50.8)	2.0 (50.8)	1.1 (28)	1.1 (28)
	B	26.8 (681)	31.5 (800)	35.5 (902)	38.6 (981)	39.2 (996)	39.2 (996)
	C	27.3 (694)	31.5 (800)	37.0 (940)	39.5 (1004)	44.1 (1121)	48.1 (1222)
	D	30.9 (785)	35.3 (897)	42.3 (1075)	44.7 (1136)	47.1 (1197)	9.3 (237)
	E	9.3 (237)	9.3 (237)	9.3 (237)	9.3 (237)	9.3 (237)	9.3 (237)

WESTERN AUSTRALIA

7/15 Walters Drive
Osbourne Park WA 6017
T: 08 9445 7744
enquiry@speedqueenwa.com.au

NEW SOUTH WALES & ACT

245 Rawson Street
Auburn NSW 2144
T: 02 9748 2155
enquiry@speedqueenlaundry.com.au

SOUTH AUSTRALIA & NT

385-387 Main North Road
Enfield SA 5085
T: 08 7095 0336
sa@speedqueenlaundry.com.au

QUEENSLAND

2/18 Gravel Pit Road
Darra QLD 4076
T: 07 3376 3869 *Home retail
qld@speedqueenlaundry.com.au